

Wheel game changer?

Mercedes announced an all-new black liveried car for the 2020 Formula One season in support of #BlackLivesMatter.

Mercedes have improved on a car that was already the one to beat, particularly with their innovative dual-axis steering (DAS) system. The Straits Times looks at the key changes to the W11, which is expected to help the Silver Arrows charge to a seventh straight constructors' title.

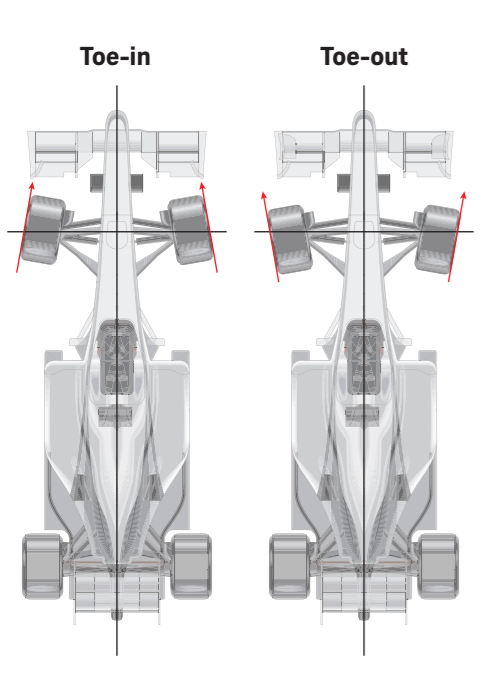
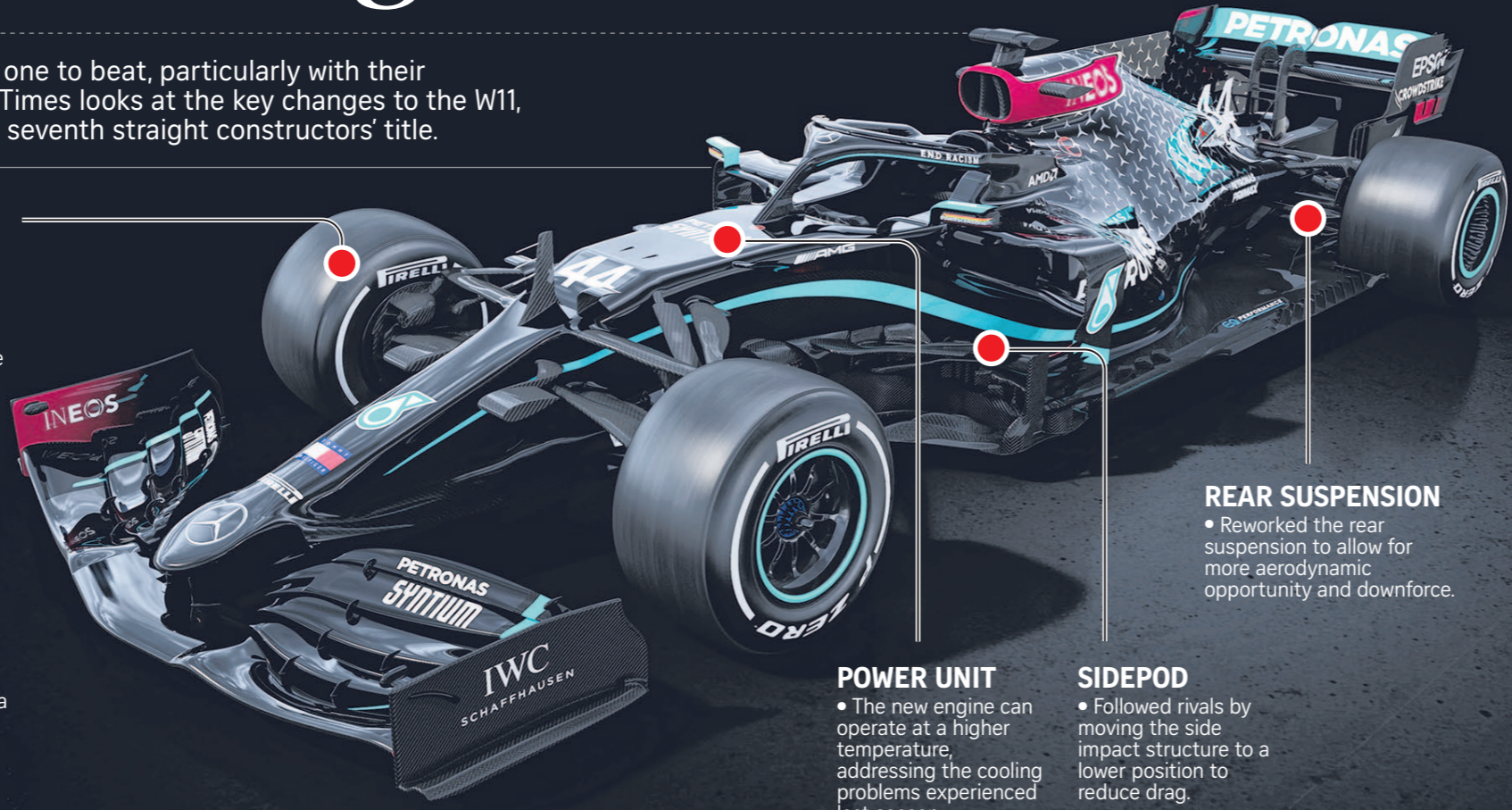

FRONT WHEEL

- DAS changes the angle of the wheels. It is activated by pulling or pushing the steering wheel. Pulling will cause the wheels to move into a straight position. Pushing will return them to their traditional toe-out position. Toe-out provides stability through the corners but wears the inside of the tyres. Toe-in enables the tyres to heat up more evenly when driving in a straight line. A reduction in tyre wear could result in a higher top speed on tracks with longer straights.

REAR SUSPENSION

- Reworked the rear suspension to allow for more aerodynamic opportunity and downforce.

POWER UNIT

- The new engine can operate at a higher temperature, addressing the cooling problems experienced last season.

SIDEPOD

- Followed rivals by moving the side impact structure to a lower position to reduce drag.

THE LINE-UP

MERCEDES

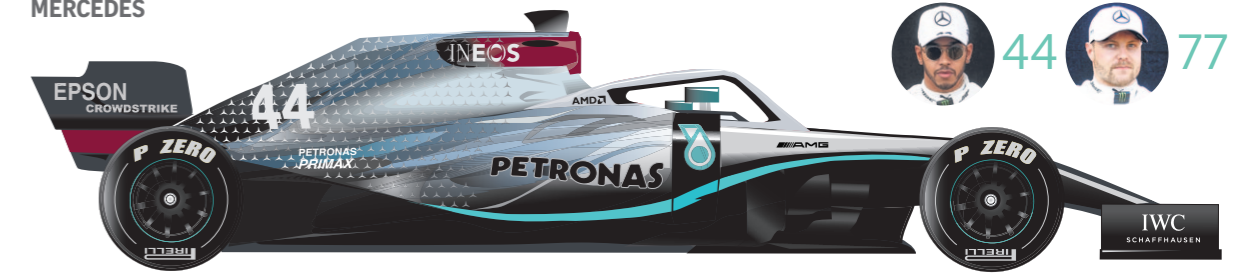

FERRARI

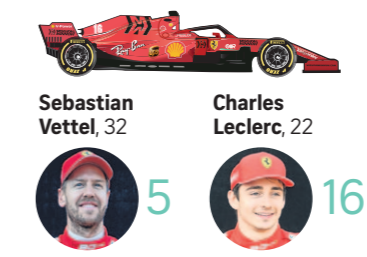

RED BULL

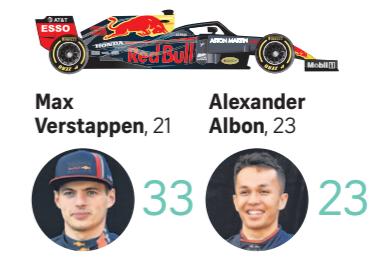

RACING POINT

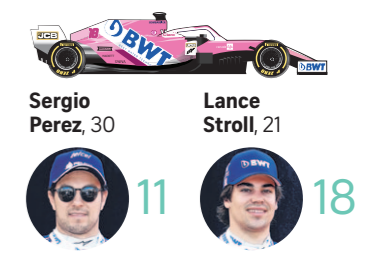

RENAULT

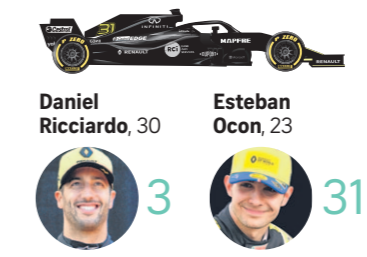

WILLIAMS

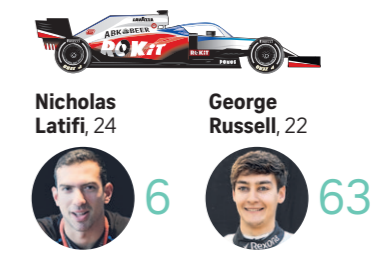

MCLAREN

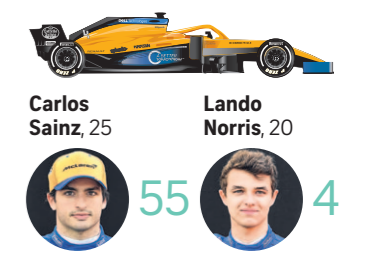

ALPHATAURI

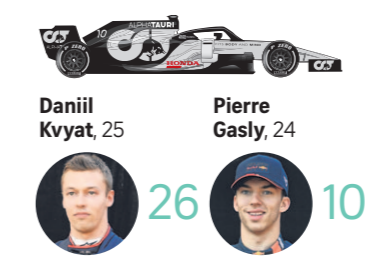

HAAS

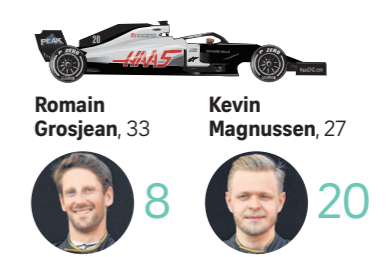

ALFA ROMEO

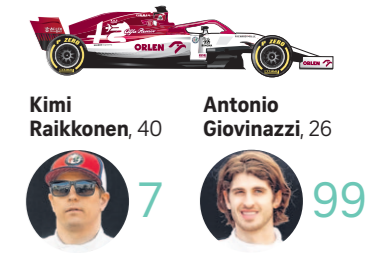

THE RACES

- 1 Austria**
Austrian Grand Prix
Red Bull Ring - July 3-5
- 2 Austria**
Steiermark Grand Prix
Red Bull Ring - July 10-12
- 3 Hungary**
Hungarian Grand Prix
Hungaroring - July 17-19
- 4 Britain**
British Grand Prix
Silverstone - July 31-Aug 2
- 5 Britain**
70th Anniversary Grand Prix
Silverstone - Aug 7-9
- 6 Spain**
Spanish Grand Prix
Circuit de Catalunya - Aug 14-16
- 7 Belgium**
Belgian Grand Prix
Spa-Francorchamps - Aug 28-30
- 8 Italy**
Italian Grand Prix
Monza - Sept 4-6